

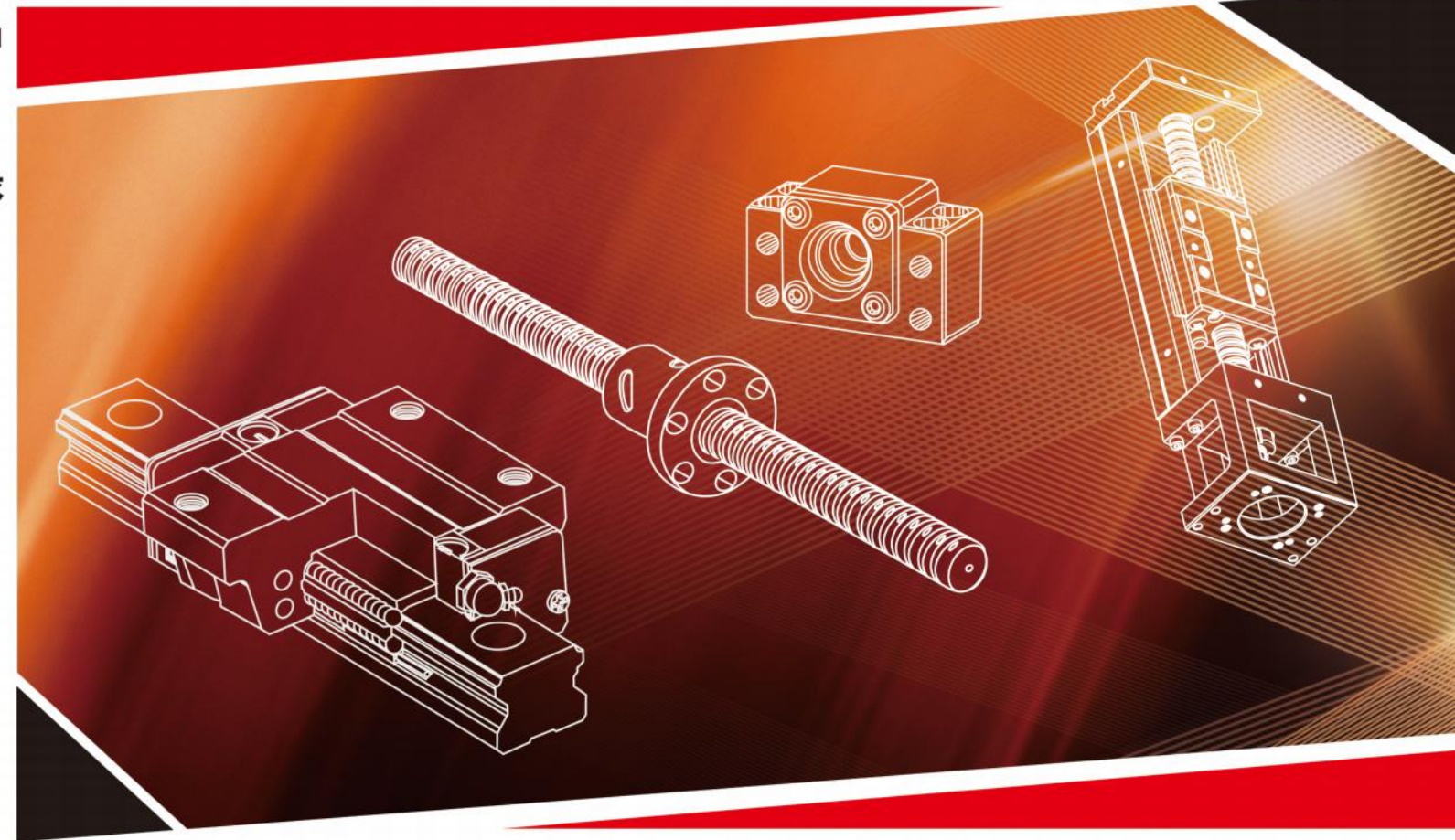

綜合產品目錄

**LINEAR GUIDEWAYS BALL SCREWS**

**SUPPORT UNIT OF BALL SCREW LINEAR MODULE**



線性導軌·滾珠螺桿·螺桿支撐座·線性模組

### Jiangsu Zcf Precision Technology Co.,Ltd

Add: No.83, middle Wanping road,Wanping community, Wujiang, Suzhou,Jiangsu, China-215223

Web: [www.js-zcf.com](http://www.js-zcf.com)

E-mail: [info@js-zcf.com](mailto:info@js-zcf.com)

Tel: 0138-1489 6944

本型录内容仅供参考，如与实物不符，请以实物为准。本公司保留产品尺寸变更或停用之权利。

Note:the appearance and specification may be changed without prior notice only if the requirement improves performance.

**Jiangsu Zcf Precision Technology Co.,Ltd**

# 滾珠螺桿

## BALL SCREWS



### Selection of ball screw

- Use condition
- Design of accuracy:
- Screw shaft design
- Drive Torque
- Nut design
- Rigidity review
- Positioning accuracy
- Design of life
- Attention

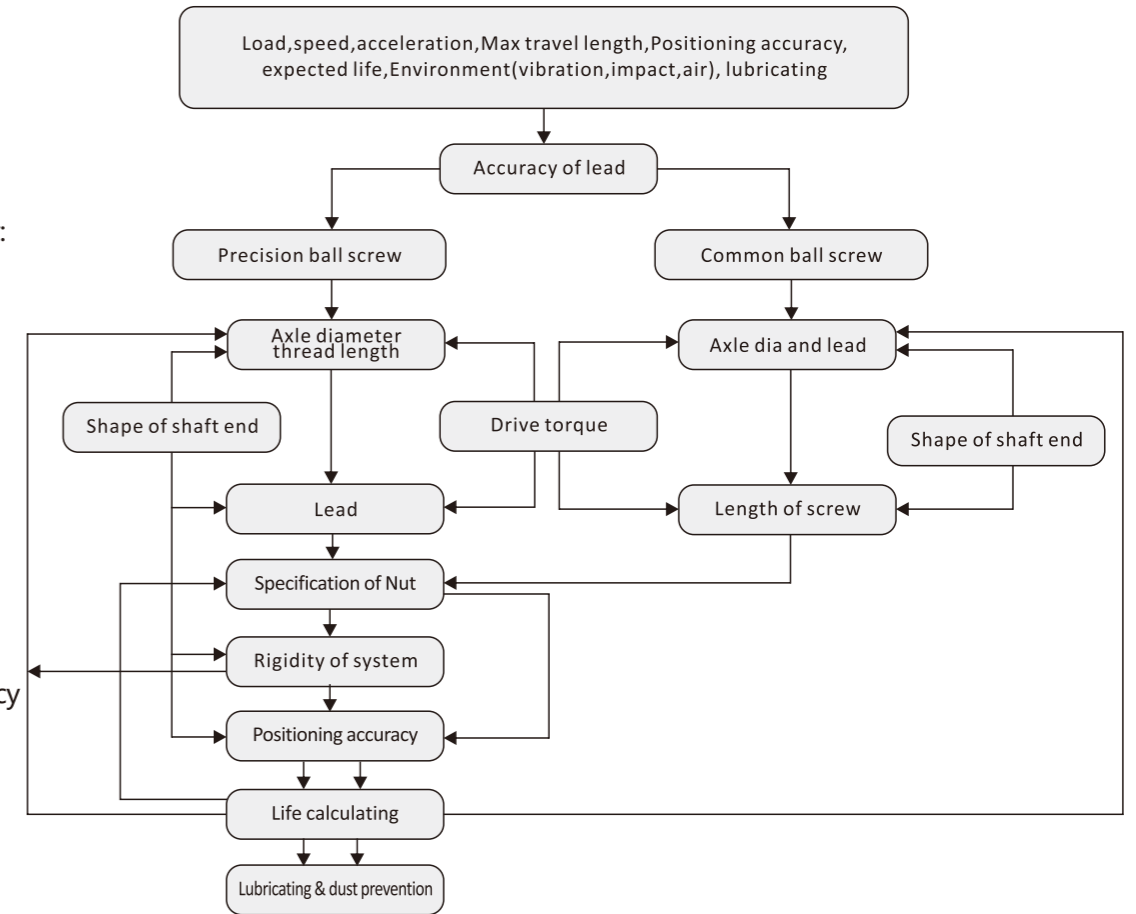

Ball screw size :

Dia \ Lead	1	2	2.5	3	4	5	5.08	6	10	12.7	16	20	25	32	40	50
6	◎															
8	◎	◎	◎													
10		◎		◎	◎											
12		◎			◎	◎			◎	◎						
14		◎			◎	◎										
15												◎				
16		◎			◎	◎	◎		◎		◎					
20					○	◎			◎			◎				
25					◎	◎			◎			◎	◎			
32					○	◎		◎	◎			◎		◎		
40						◎		◎	◎			◎			◎	
50						○			◎			◎				◎
63									◎			◎			◎	
80									◎			◎				

• Rolling type ○Grinding type

# Ball Screws

## 内(外)循環式滾珠螺桿規格定義

2R25-25A2-2-FSED-2000-2500-0.05-R-P2



滾珠螺桿

# Ball Screws

## 1.1 TYPE:FSU(DIN69051)

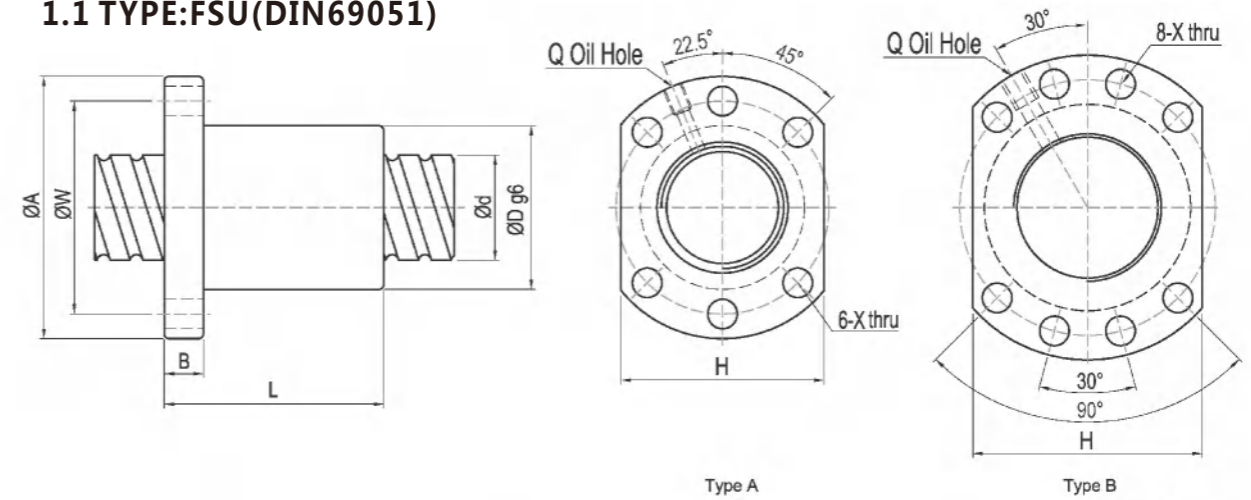

Unit:mm

model no.	Specification														
	d	l	Da	D	A	B	L	W	X	Type	H	Q	n	Ca(Kgf)	Coa(kgf)
1604-4	16	4	2.381	28	48	10	45	38	5.5	A	40	M6	T4	944	1254
★ 1605-3	16	5	3.175	28	48	10	42	38	5.5	A	40	M6	T3	1049	1144
★ 1605-4	16	5	3.175	28	48	10	50	38	5.5	A	40	M6	T4	1344	1525
1610-3	16	10	3.175	28	48	12	65	38	5.5	A	40	M6	T3	1084	1232
2005-3	20	5	3.175	36	58	10	47	47	6.6	A	44	M6	T3	1181	1496
★ 2005-4	20	5	3.175	36	58	10	53	47	6.6	A	44	M6	T4	1512	1995
2006-3	20	6	3.969	36	58	10	52	47	6.6	A	44	M6	T3	1569	1788
2010-3	20	10	3.969	36	58	10	68	47	6.6	A	44	M6	T3	1621	1925
2504-4	25	4	2.381	40	62	11	46	51	6.6	A	48	M6	T4	1178	2046
2505-3	25	5	3.175	40	62	10	47	51	6.6	A	48	M6	T3	1330	1936
★ 2505-4	25	5	3.175	40	62	10	53	51	6.6	A	48	M6	T4	1704	2581
2510-3	25	10	4.762	40	62	12	75	51	6.6	A	48	M6	T3	2250	2772
2510-4	25	10	4.762	40	62	12	85	51	6.6	A	48	M6	T4	2881	3695
★ 3205-4	32	5	3.175	50	80	12	53	65	9	A	62	M6	T4	1924	3403
3206-4	32	6	3.969	50	80	12	58	65	9	A	62	M6	T4	2598	4217
3210-3	32	10	6.35	50	80	16	77.5	65	9	A	62	M6	T3	3775	5877
3210-4	32	10	6.35	50	80	16	90	65	9	A	62	M6	T4	4834	7835
★ 4005-4	40	5	3.175	63	93	16	56	78	9	B	70	M8	T4	2142	4342
4006-4	40	6	3.969	63	93	14	60	78	9	B	70	M6	T4	2877	5318
4010-4	40	10	6.35	63	93	18	93	78	9	B	70	M8	T4	5399	10074
5006-4	50	6	3.969	75	110	15	62	93	11	B	85	M8	T4	3203	6784
5010-4	50	10	6.35	75	110	18	93	93	11	B	85	M8	T4	5933	12313
6310-4	63	10	6.35	90	125	18	98	108	11	B	95	M8	T4	6700	16230
6320-3	63	20	9.525	95	135	20	138	115	13.5	B	100	M8	T3	8957	17945
8010-4	80	10	6.35	105	145	20	98	125	13.5	B	110	M8	T4	7547	21268
8020-3	80	20	9.525	125	165	25	143	145	13.5	B	130	M8	T3	10168	23611

Left thread is optional

# Ball Screws

## 1.2 TYPE:FDU(DIN69051)

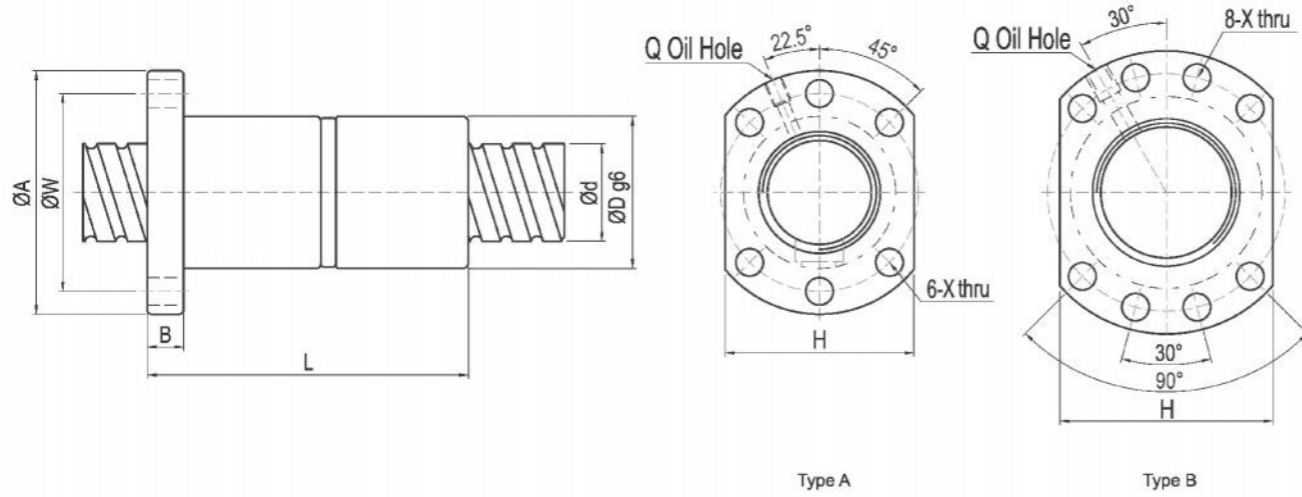

滚珠螺杆

Unit:mm

model no.	Specification														
	d	l	Da	D	A	B	L	W	X	Type	H	Q	n	Ca(Kgf)	Coa(kgf)
★ 1605-3	16	5	3.175	28	48	10	80	38	5.5	A	40	M6	T3	1049	1144
★ 2005-4	20	5	3.175	36	58	12	92	47	6.6	A	44	M6	T4	1512	1995
★ 2505-4	25	5	3.175	40	62	12	92	51	6.6	A	48	M6	T4	1704	2581
2510-4	25	10	4.762	40	62	12	153	51	6.6	A	48	M6	T4	2881	3695
★ 3205-4	32	5	3.175	50	80	12	92	65	9	A	62	M6	T4	1924	3403
3210-4	32	10	6.35	50	80	16	160	65	9	A	62	M6	T4	4834	7835
4005-4	40	5	3.175	63	93	15	96	78	9	B	70	M8	T4	2142	4342
4010-4	40	10	6.35	63	93	18	162	78	9	B	70	M8	T4	5399	10074
5010-4	50	10	6.35	75	110	16	162	93	11	B	85	M8	T4	5933	12313
6310-4	63	10	6.35	90	125	18	182	108	11	B	95	M8	T4	6700	16230
6320-3	63	20	9.525	95	135	20	253	115	13.5	B	100	M8	T3	8957	17945
8010-4	80	10	6.35	105	145	20	182	125	13.5	B	110	M8	T4	7547	21268
8020-3	80	20	9.525	125	165	25	253	145	13.5	B	130	M8	T3	10168	23611

Left thread is optional

# Ball Screws

## 1.3 TYPE:FSI

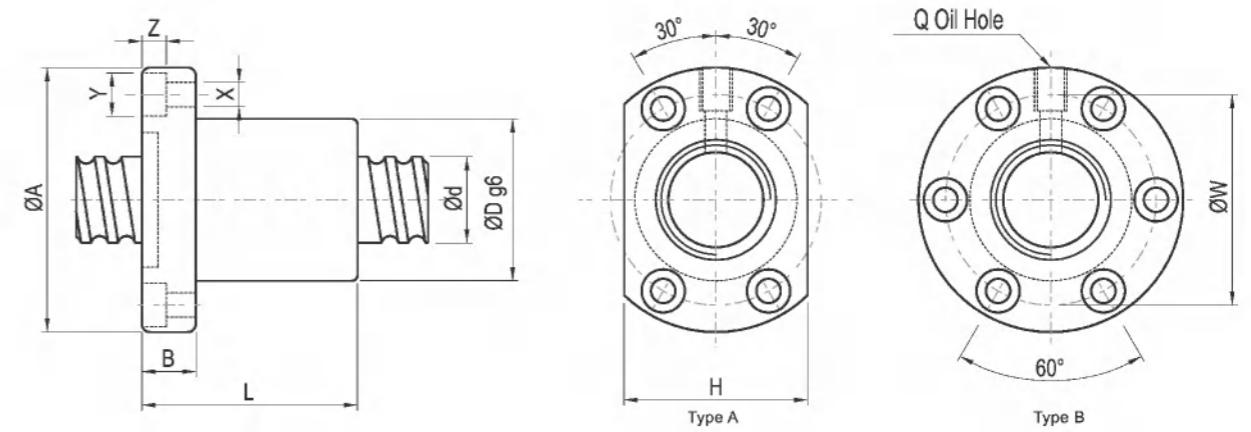

Unit:mm

model no.	Specification																
	d	l	Da	D	A	B	L	W	X	Y	Z	Type	H	Q	n	Ca(Kgf)	Coa(kgf)
1404-4	14	4	2.381	26	46	10	47	36	4.5	8	4.5	A	34	M6	T4	875	1056
1405-3	14	5	3.175	26	46	10	45	36	4.5	8	4.5	A	34	M6	T3	1013	1056
1604-4	16	4	2.381	30	49	10	45	39	4.5	8	4.5	A	34	M6	T4	944	1254
★ 1605-3	16	5	3.175	30	49	10	42	39	4.5	8	4.5	A	34	M6	T3	1049	1144
★ 1605-4	16	5	3.175	30	49	10	50	39	4.5	8	4.5	A	34	M6	T4	1344	1525
1610-3	16	10	3.175	34	58	10	65	45	5.5	9.5	5.5	A	36	M6	T3	1084	1232
★ 2005-4	20	5	3.175	34	57	12	53	45	5.5	9.5	5.5	A	40	M6	T4	1512	1995
2504-4	25	4	2.381	40	63	11	46	51	5.5	9.5	5.5	A	46	M6	T4	1178	2046
★ 2505-4	25	5	3.175	40	63	12	53	51	5.5	9.5	5.5	A	46	M8	T4	1704	2581
2510-4	25	10	4.762	46	72	12	85	58	6.5	11	6.5	A	52	M6	T4	2881	3695
★ 3205-4	32	5	3.175	46	72	12	53	58	6.5	11	6.5	A	52	M8	T4	1924	3403
3206-4	32	6	3.969	62	89	12	63	75	6.5	11	6.5	B	-	M8	T4	2598	4217
3210-4	32	10	6.35	54	88	16	90	70	9	14	8.5	A	62	M8	T4	4834	7835
★ 4005-4	40	5	3.175	56	90	16	56	72	9	14	8.5	A	64	M8	T4	2142	4342
4010-4	40	10	6.35	62	104	18	93	82	11	17.5	11	A	70	M8	T4	5399	10074
5010-4	50	10	6.35	72	114	18	93	92	11	17.5	11	A	82	M8	T4	5933	12313
6310-4	63	10	6.35	85	131	22	100	107	14	20	13	B	-	M8	T4	6700	16230
6320-3	63	20	9.525	95	153	23	130	123	18	26	17.5	B	-	M8	T3	8957	17945
8010-4	80	10	6.35	105	150	22	92	127	14	20	13	B	-	M8	T4	7547	21268
8020-3	80	20	9.525	115	173	23	130	143	18	26	17.5	B	-	M8	T3	10168	23611

Left thread is optional

# Ball Screws

## 1.4 TYPE:FDI

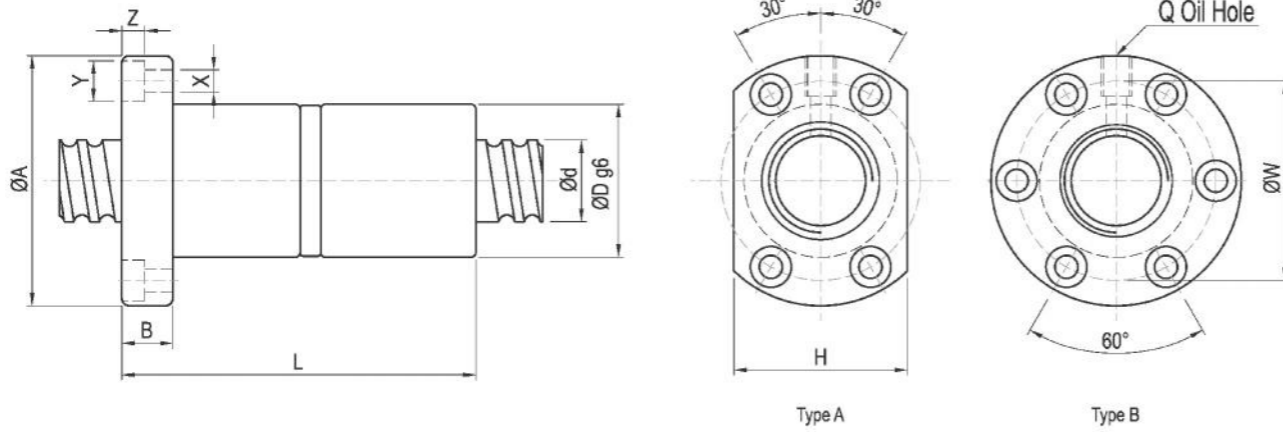

滚珠螺杆

Unit:mm

model no.	Specification																
	d	l	Da	D	A	B	L	W	X	Y	Z	Type	H	Q	n	Ca(Kgf)	Coa(kgf)
★ 1605-3	16	5	3.175	30	49	10	80	39	4.5	8	4.5	A	34	M6	T3	1049	1144
★ 2005-4	20	5	3.175	34	57	12	92	45	5.5	9.5	5.5	A	40	M6	T4	1512	1995
★ 2505-4	25	5	3.175	40	63	12	92	51	5.5	9.5	5.5	A	46	M8	T4	1704	2581
2510-4	25	10	4.762	46	72	12	156	58	6.5	11	6.5	A	52	M6	T4	2881	3695
★ 3205-4	32	5	3.175	46	72	12	92	58	6.5	11	6.5	A	52	M8	T4	1924	3403
3210-4	32	10	6.35	54	88	16	160	70	9	14	8.5	A	62	M8	T4	4834	7835
★ 4005-4	40	5	3.175	56	90	16	96	72	9	14	8.5	A	64	M8	T4	2142	4342
4010-4	40	10	6.35	62	104	18	162	82	11	17.5	11	A	70	M8	T4	5399	10074
5010-4	50	10	6.35	72	114	18	162	92	11	17.5	11	A	82	M8	T4	5933	12313
6310-4	63	10	6.35	85	131	22	182	107	14	20	13	B	-	M8	T4	6700	16230
6320-3	63	20	9.525	95	153	23	253	123	18	26	17.5	B	-	M8	T3	8957	17945
8010-4	80	10	6.35	105	150	22	182	127	14	20	13	B	-	M8	T4	7547	21268
8020-3	80	20	9.525	115	173	23	253	143	18	26	17.5	B	-	M8	T3	10168	23611

Left thread is optional

# Ball Screws

## 1.5 TYPE:FSC

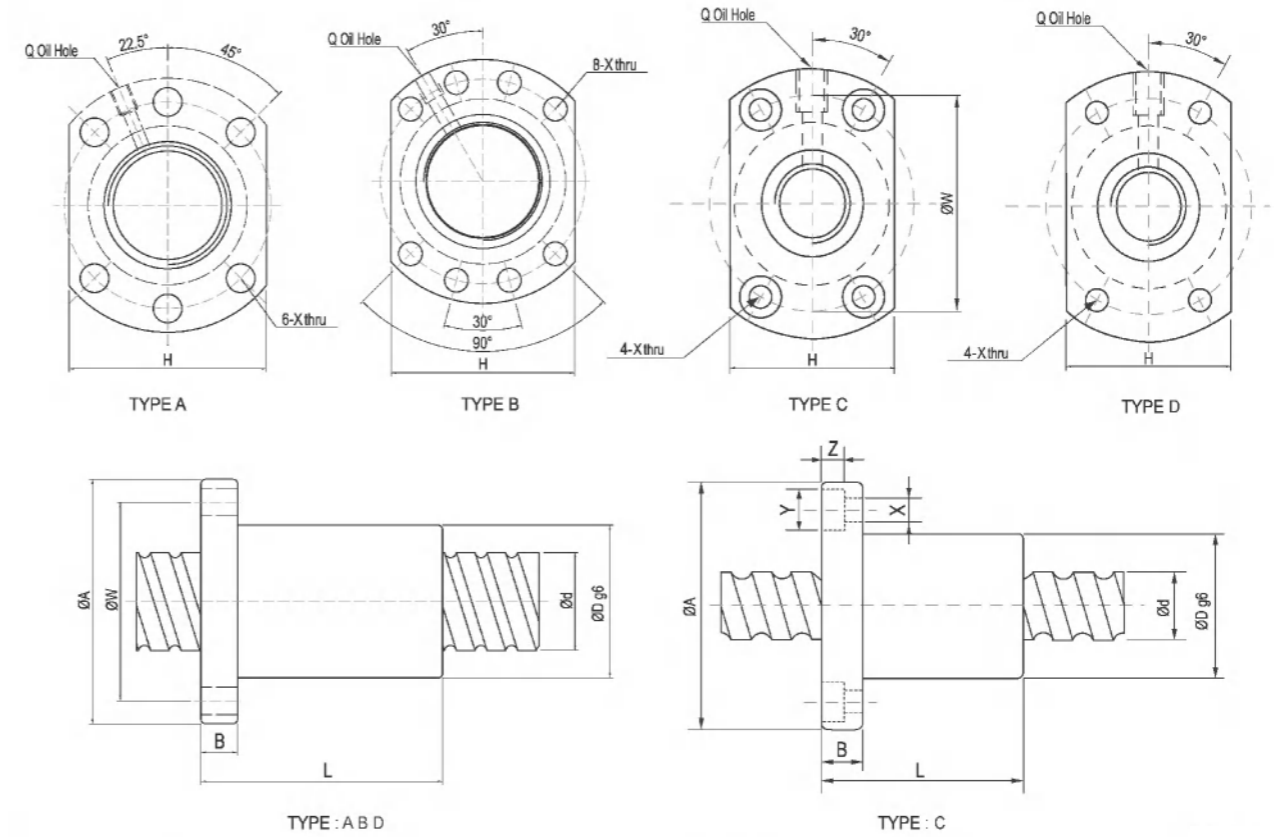

Unit:mm

model no.	Specification																
	d	l	Da	D	A	B	L	W	X	Y	Z	Type	H	Q	n	Ca(Kgf)	Coa(kgf)
1210-2	12	10	2	30	50	10	40	40	4.5	8	4.5	C	32	M6	T2	390	466
1520-2	15	20	3.175	34	55	12	57	45	6	-	-	D	34	M6	T2	833	997
1610-3	16	10	3.175	28	48	12	43	38	5.5	-	-	A	40	M6	T3	1180	1496
1616-3	16	16	3.175	28	48	12	61	38	5.5	-	-	A	40	M6	T3	1180	1496
2010-2	20	10	3.969	46	74	13	54	59	6.6	11	5.5	C	46	M6	T2	1246	1559
2020-4	20	20	3.175	36	58	10	55	47	6.6	-	-	A	44	M6	T4	1659	2464
▲ 2510-4	25	10	3.5	40	62	12	64	51	6.6	-	-	A	48	M6	T4	2067	3280
2525-4	25	25	3.969	47	74	12	67	60	6.6	-	-	A	56	M6	T4	2481	3851
3220-3	32	20	3.969	50	80	13	78	65	9	-	-	A	62	M6	T3	2141	3576
3232-4	32	32	4.762	56	86	16	82	71	9	-	-	A	65	M6	T4	3585	6071
4020-3	40	20	5.556	63	93	15	83	78	9	-	-	B	70	M8	T3	3782	6468
4040-4	40	40	6.35	65	95	18	100	80	9	-	-	B	72	M8	T4	5778	11753
5020-5	50	20	6.35	75	110	18	121	93	11	-	-	B	85	M8	T5	7737	18189

Ball dia.:3.5mm Please select ball screw with 3.5mm ball dia.

# Ball Screws

## 1.6 TYPE:FSE

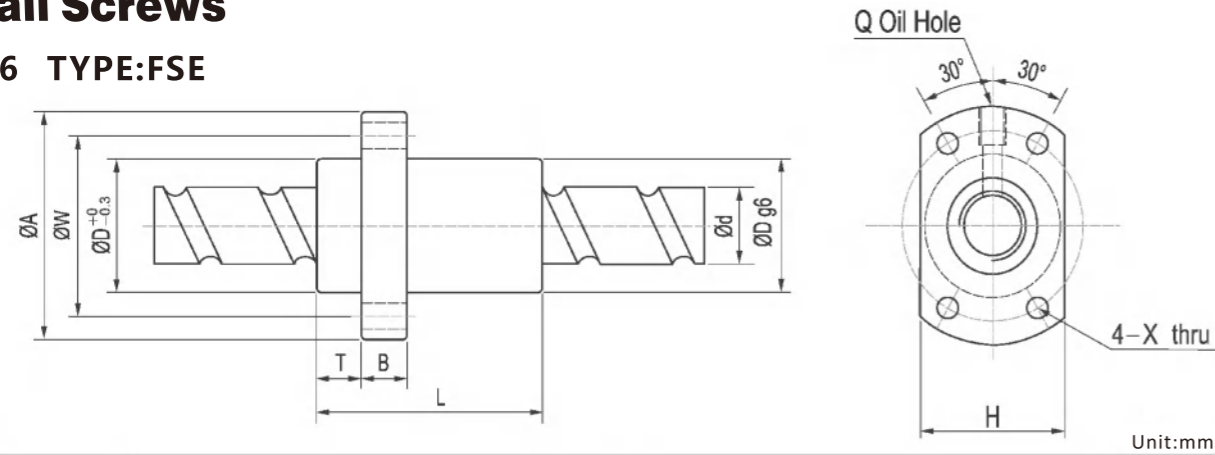

model no.	Specification														
	d	l	Da	D	A	B	T	L	W	X	H	Q	n	Ca(Kgf)	Coa(kgf)
1616-2	16	16	3.175	32	53	10	10.5	48	42	4.5	38	M6	A2	1512	1995
★ 2020-2	20	20	3.175	39	62	10	10.8	55	50	5.5	46	M6	A2	1659	2464
2520-2	25	20	3.5	47	74	12	11	65	60	6.6	49	M6	A2	2106	3422
2525-2	25	25	3.969	47	74	12	11.2	67	60	6.6	56	M6	A2	2481	3851
3232-2	32	32	4.762	58	92	15	14	82	74	9	68	M6	A2	3585	6071
4040-2	40	40	6.35	73	114	17	17	100	93	11	84	M6	A2	5778	11753
5050-2	50	50	7.938	90	135	20	21.5	125	112	14	92	M6	A2	8819	19241

Left thread is optional

## 1.7 TYPE:FSB

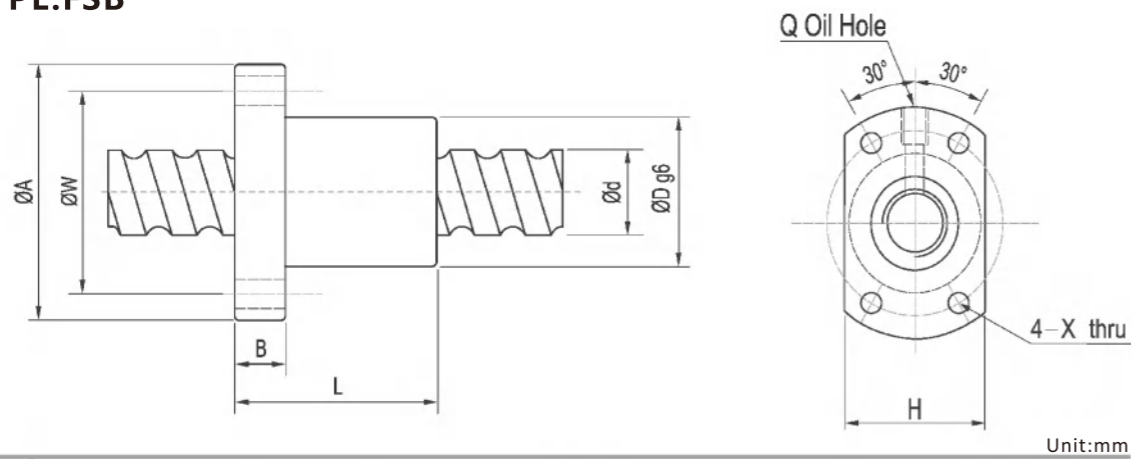

model no.	Specification													
	d	l	Da	D	A	B	L	W	X	H	Q	n	Ca(Kgf)	Coa(kgf)
1404-3	14	4	2.381	31	50	10	40	40	4.5	37	M6	T3	684	792
1405-3	14	5	3.175	32	50	10	45	40	4.5	38	M6	T3	1013	1056
1605-3	16	5	3.175	34	54	10	42	44	4.5	40	M6	T3	1049	1144
2005-3	20	5	3.175	40	60	10	47	50	4.5	46	M6	T3	1181	1496
2505-3	25	5	3.175	43	67	10	47	55	5.5	50	M6	T3	1330	1936
2510-3	25	10	4.762	60	96	15	75	78	9	72	M6	T3	2250	2772
2510-4	25	10	4.762	60	96	15	97	78	9	72	M6	T4	2881	3695
3210-3	32	10	6.35	67	103	15	78	85	9	78	M6	T3	3775	5877
3210-4	32	10	6.35	67	103	15	97	85	9	78	M6	T4	4834	7835
4010-4	40	10	6.35	76	116	17	100	96	11	88	M6	T4	5399	10074

# Ball Screws

## 1.8 TYPE:FSK

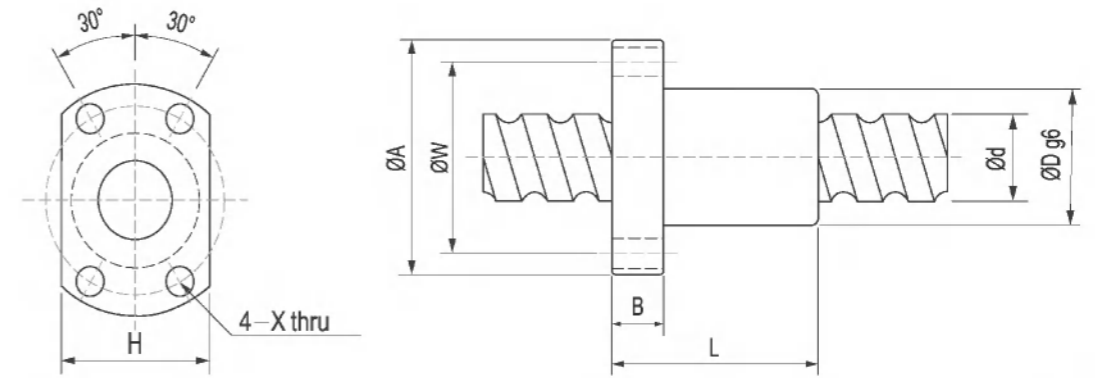

model no.	Specification													
	d	l	Da	D	A	B	L	W	X	H	n	Ca(Kgf)	Coa(kgf)	
0601-3	6	1	0.8	12	24	3.5	18	18	3.4	16	T3	111	123	
0801-3	8	1	0.8	14	27	4	20	21	3.4	18	T3	126	162	
0802-3	8	2	1.2	16	29	4	26	23	3.4	20	T3	215	239	
0825-3	8	2.5	1.2	16	29	4	26	23	3.4	20	T3	215	239	
1002-3	10	2	1.2	18	35	5	28	27	4.5	22	T3	240	302	
1004-3	10	4	2	26	46	10	35	36	4.5	28	T3	472	489	
1202-3	12	2	1.2	20	37	5	28	29	4.5	24	T3	265	377	
1204-3	12	4	2.381	28	48	6	35	39	5.5	30	T3	645	693	
1205-3	12	5	2	28	48	6	35	39	5.5	30	T3	514	594	
1402-3	14	2	1.2	21	40	6	28	31	5.5	26	T3	283	440	
1602-3	16	2	1.2	25	43	10	32	35	5.5	29	T3	300	503	

## 1.9 TYPE:RSK

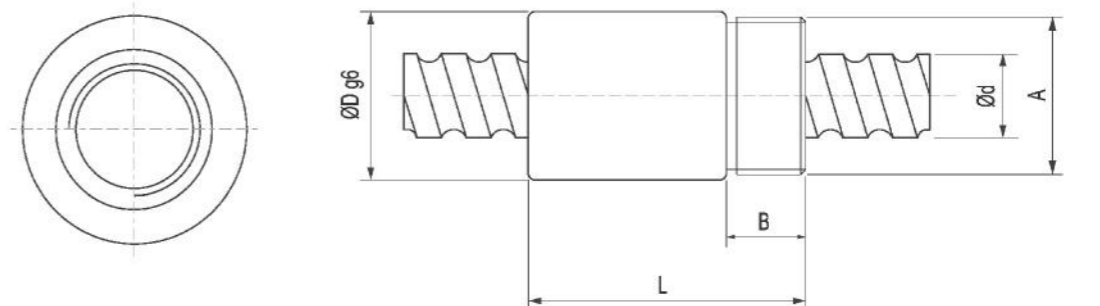

model no.	Specification										
	d	l	Da	D	A	B	L	n	Ca(Kgf)	Coa(kgf)	
0825-3	8	2.5	1.2	17.5	M15X1P	8	26	T3	215	239	
1003-3	10	3	1.8	21	M18X1P	9	29	T3	403	424	
1204-3	12	4	2.381	25.5	M20X1P	10	34	T3	645	693	
1205-3	12	5	2	25.5	M20X1P	10	39	T3	514	594	
1605-3	16	5	3.175	32.5	M26X1.5P	12	42	T3	1049	1144	